

16 15 14 13 12 11 10 9 8 7 6 5 4

DO NOT SC
IF IN DOUBT

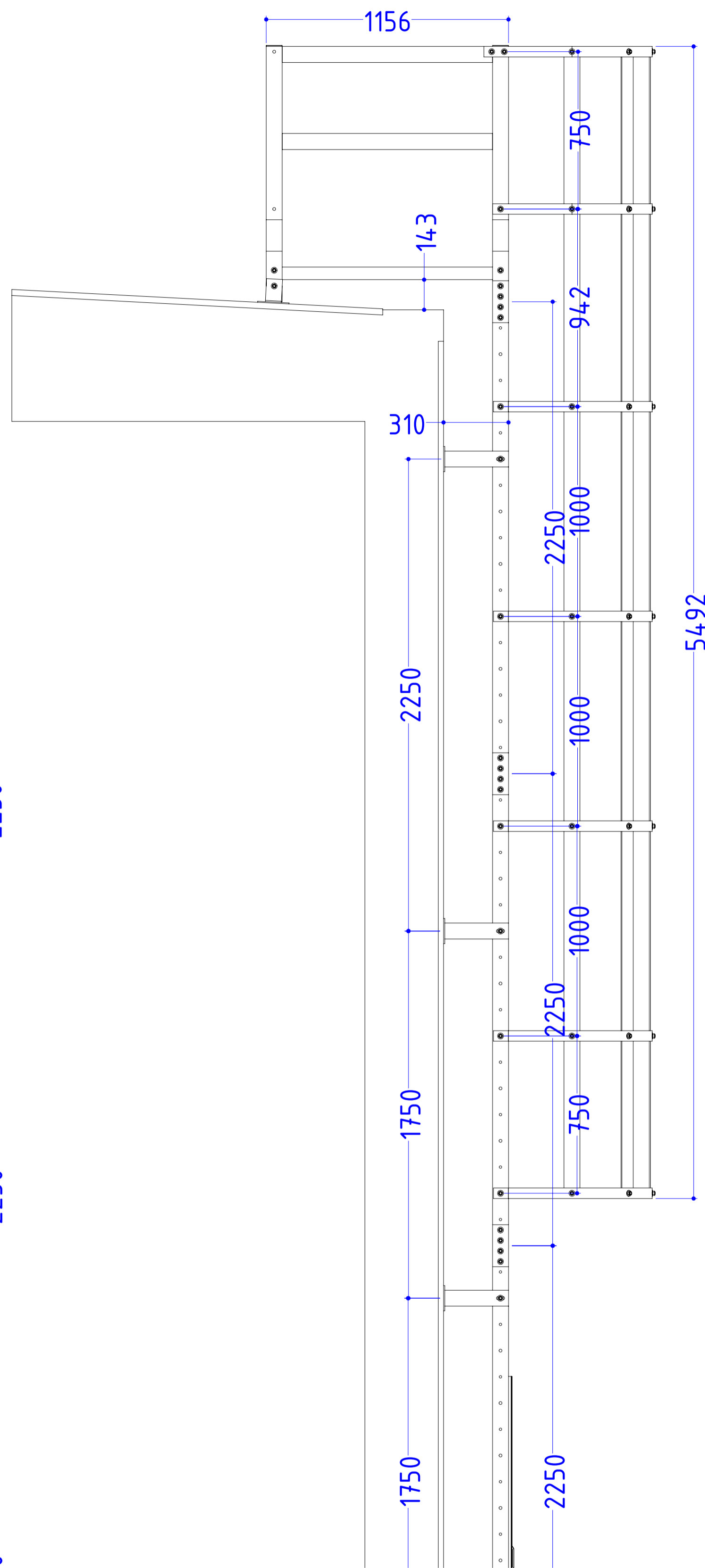
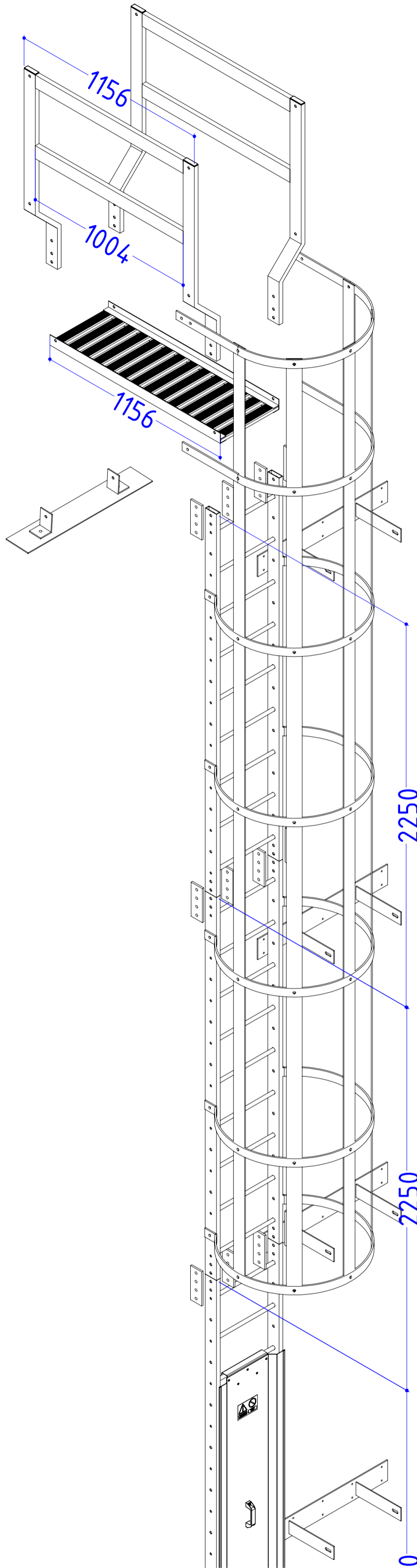
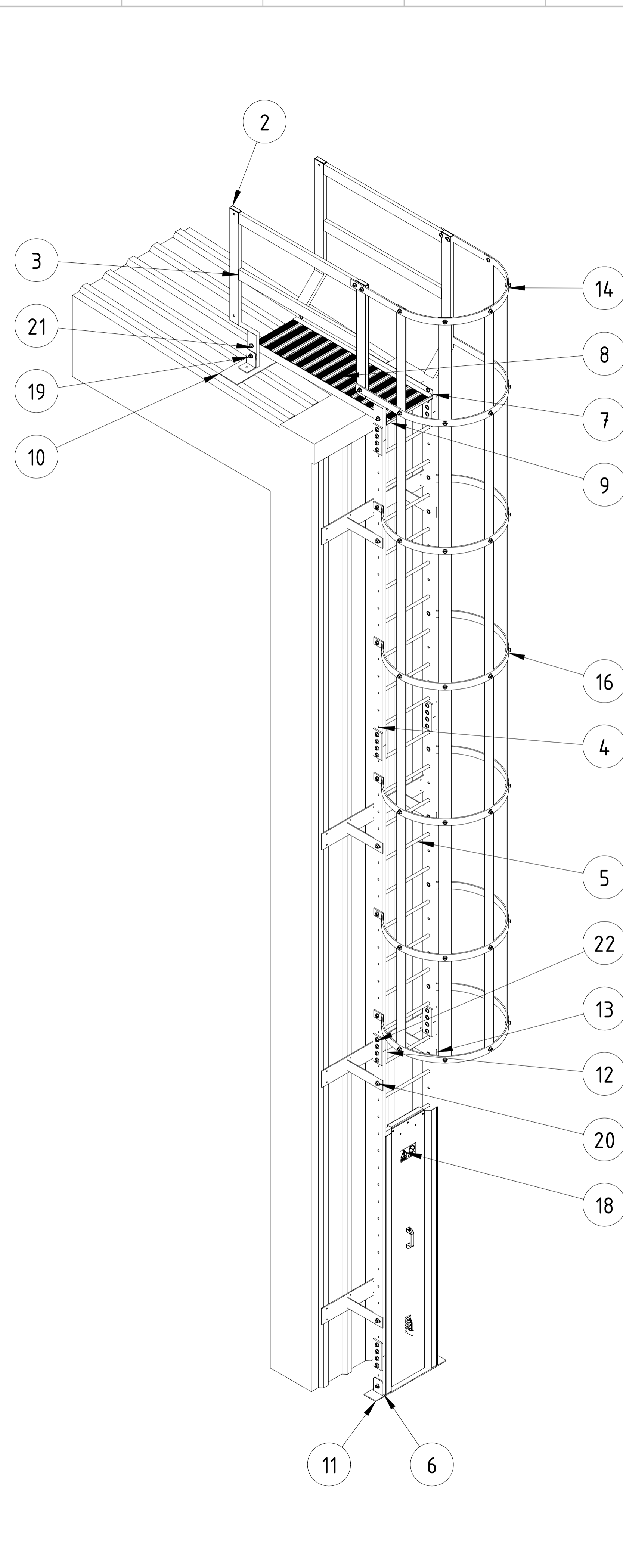

ITEM NO.	PART NAME	QTY.
1	CONNECTOR	4
2	RECTANGULAR TUBE INSERTS - REC107	4
3	CONNECTOR-FLAIR OUTS	4
4	25.4 X 76.2 X 2250 - BOX SECTION	6
5	LADDER RUNG	27
6	400	1
7	125mm- PLANK CONNECTOR	1
8	PLANK	14
9	OPPO-125mm- PLANK CONNECTOR	1
10	SPREADER PLATE-L BRACKET	1
11	SPREADER PLATE - 600 X 100 X 160 HIGH	1
12	LADDER CONNECTOR	16
13	WALL BRACKET - 880 X 120 X 310	4
14	TOP LADDER HOOP	1
15	MIDDLE LADDER HOOP	1
16	BOTTOM LADDER HOOP	5
17	HOOP STRIPS	5
18	LADDER GUARD	1
19	M12 X 50mm - BOLT	32
20	M12 NUT	99
21	M12 WASHER	198
22	M12 X 60mm - BOLT	32
23	M12 X 30mm - BOLT	35

16 15 14 13 12 11

L
K
J
H
G
F
E
D
C
B
A

16 15 14 13 12 11 10 9 8 7 6 5 4

DO NOT SC
IF IN DOUBT

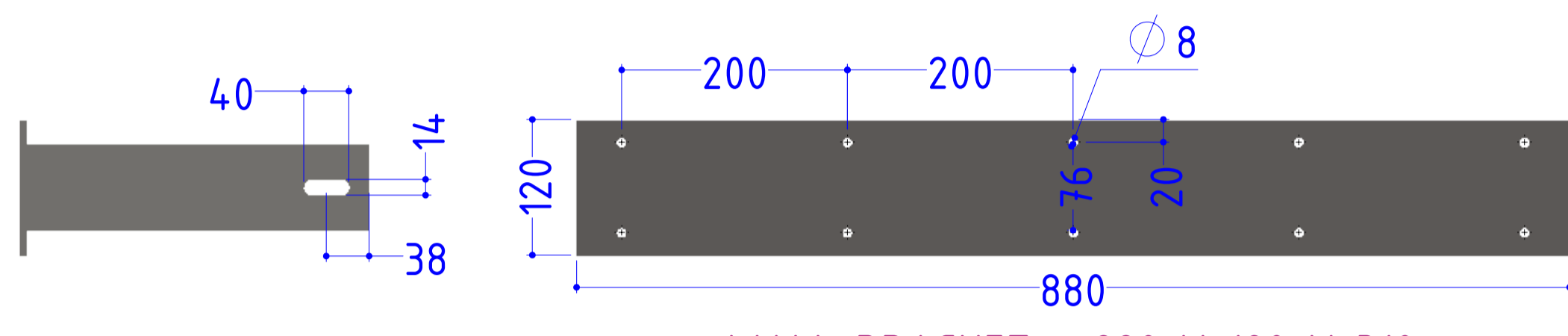
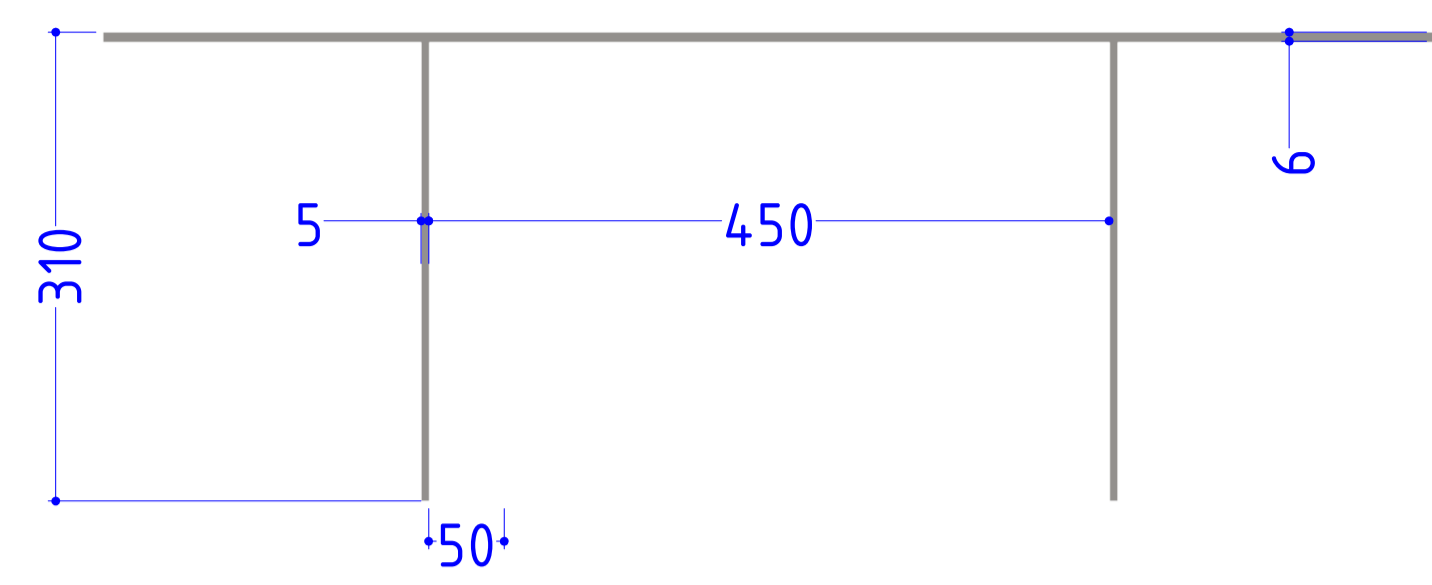

WALL BRACKET - 880 X 120 X 310

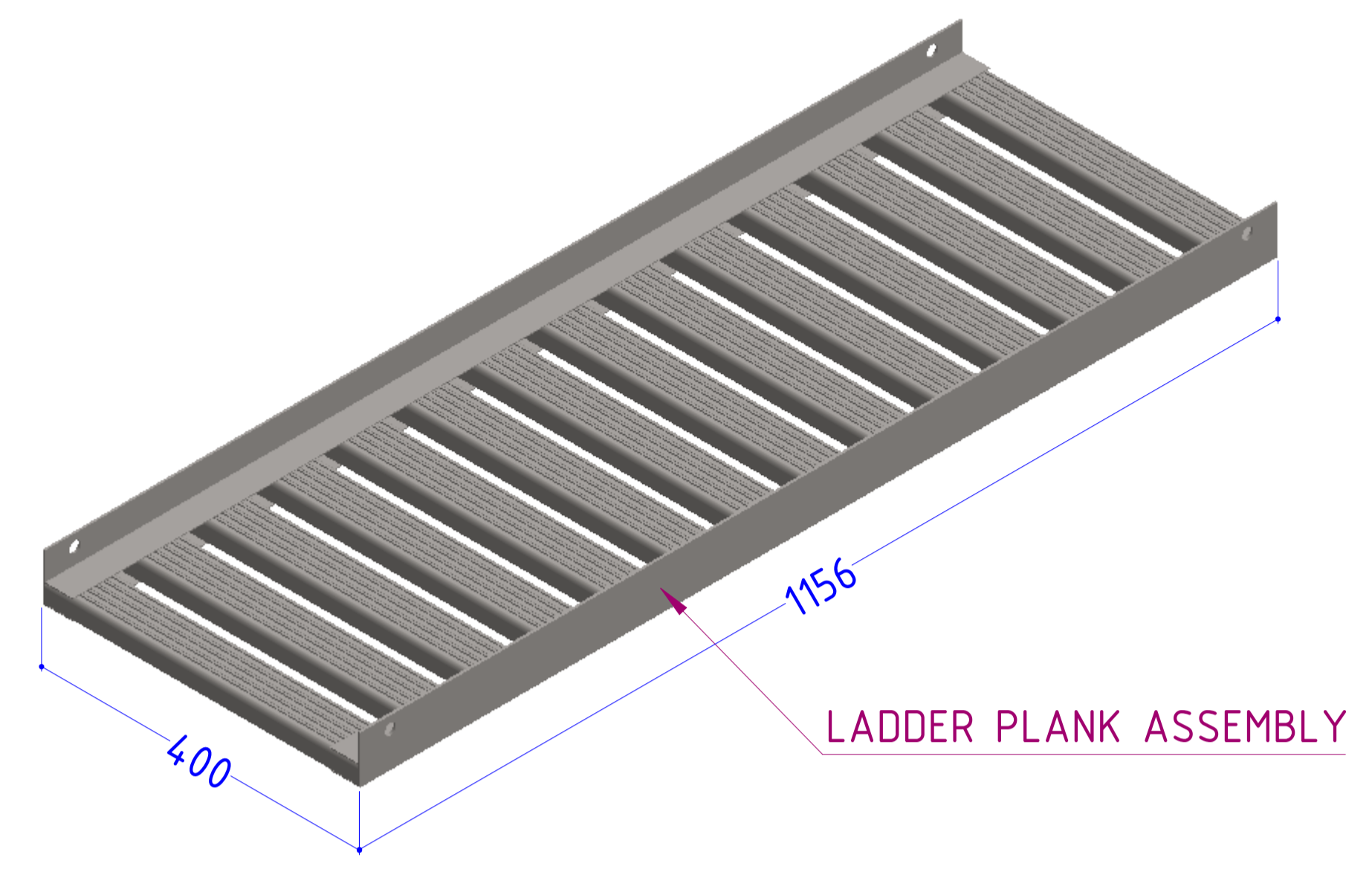

LADDER PLANK ASSEMBLY

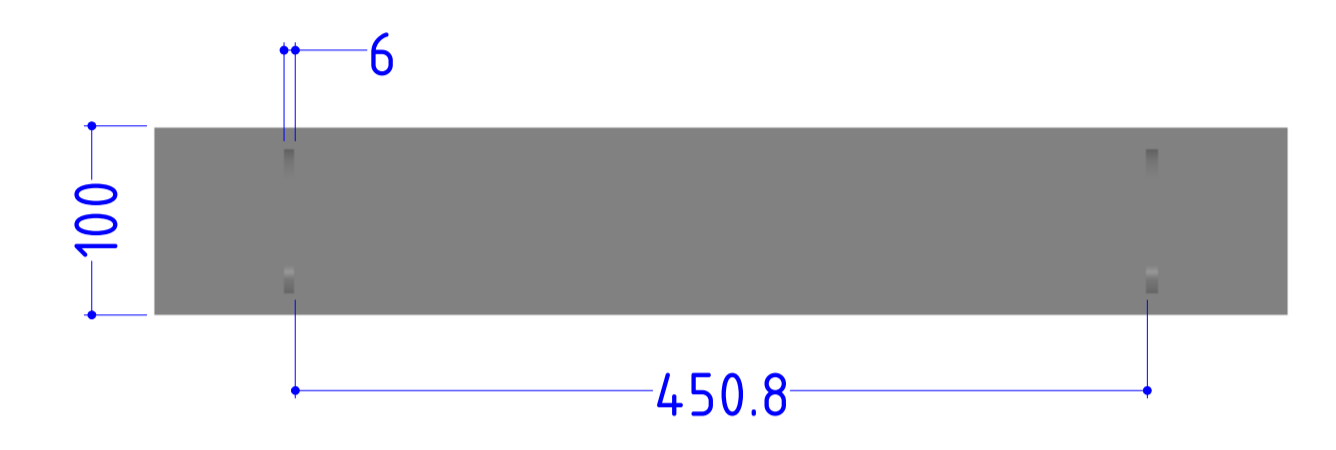

SPREADER PLATE

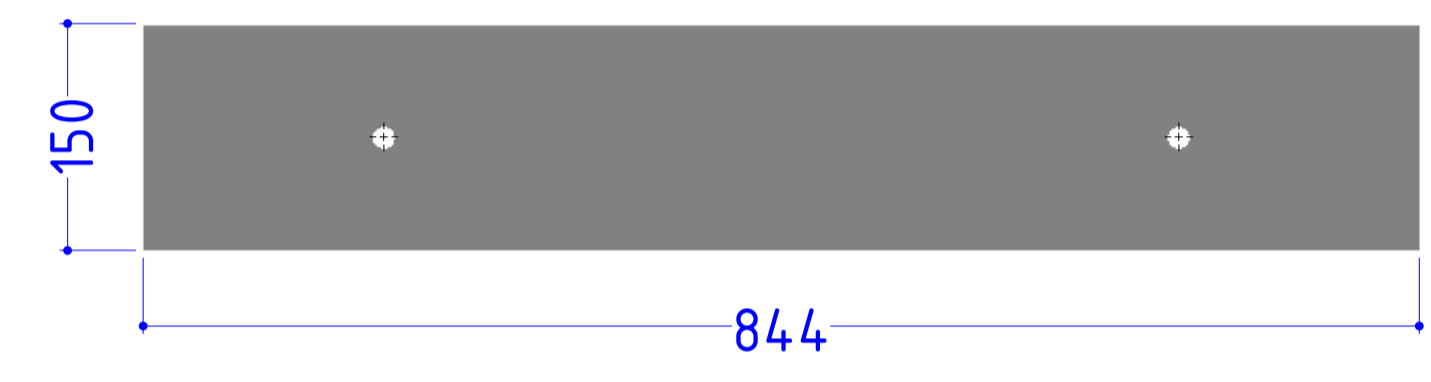

SPREADER PLATE-L BRACKET

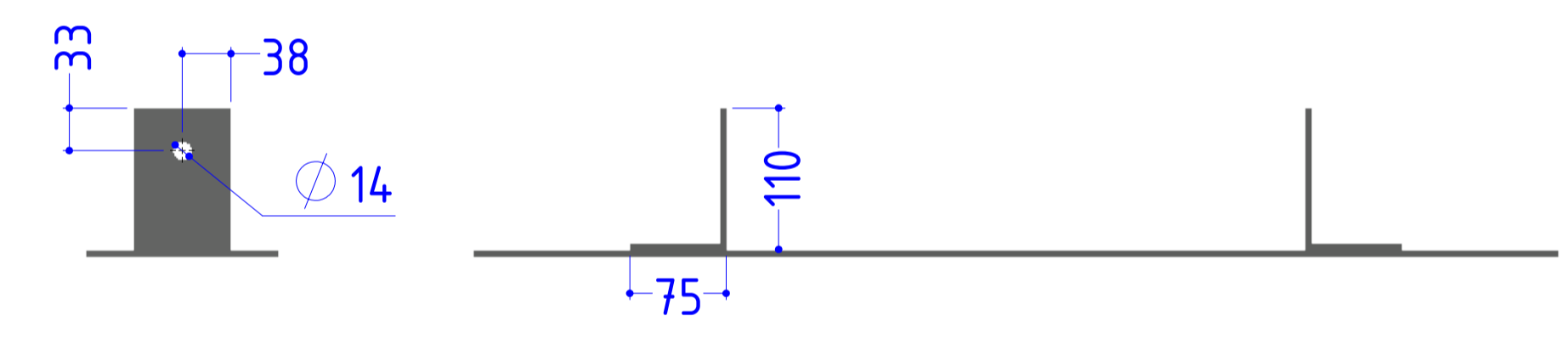
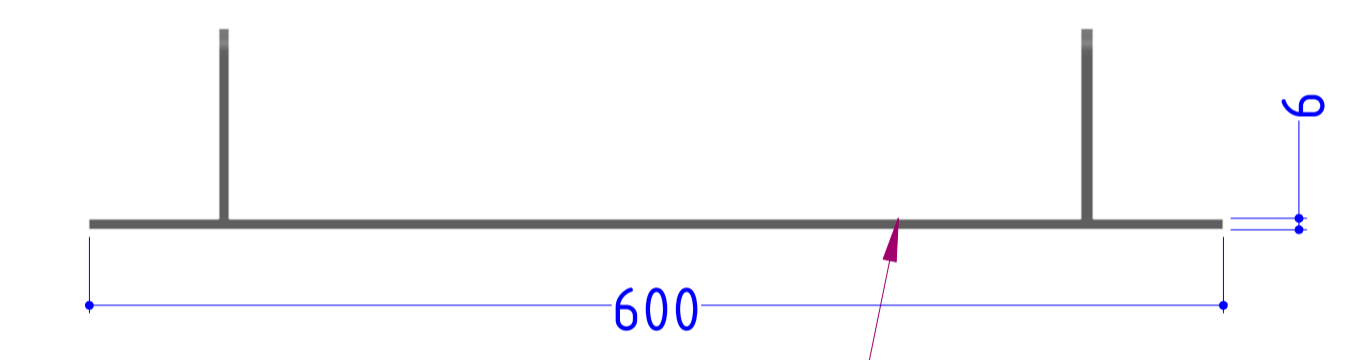
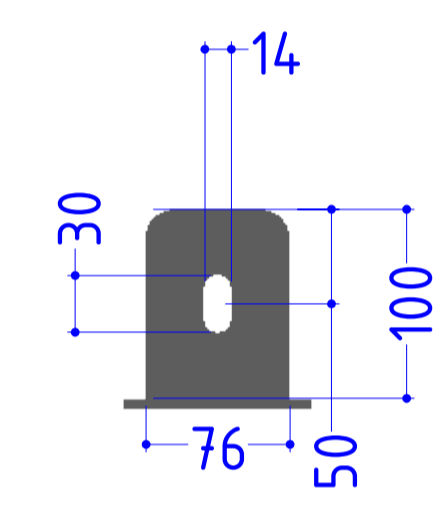

HOOP STRIPS

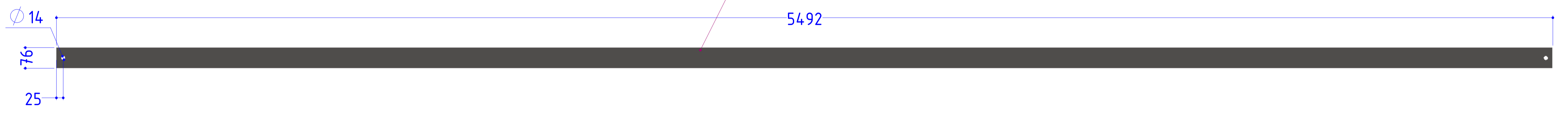

16 15 14 13 12 11

M L K J H G F E D C B A